



Introduction Established in 1987, Northern Lights have been at the forefront of the contract lighting industry for more than two decades.

Having built up their reputation from working on projects for major pub and restaurant chains such as Whitbread, Mitchells&Butlers and Marston's, today Northern Lights are one of the leading suppliers of creative lighting solutions to a wide range of sectors including pubs, restaurants, hotels and retail.

Our vision is simple – working together with our customers to deliver truly inspirational lighting solutions through our design, manufacturing and continuous innovation.

We believe the combination of our extensive product portfolio, experienced design team and multi-functional manufacturing facility can meet all of our customers' requirements.

We continually invest in the latest technology and design software. One thing will never change – our dedication to lighting and commitment to our customers.



Why Northern Lights

Extensive product range

Our extensive product range mirrors the diverse requirements of our customers. We can provide products in both contemporary and traditional styles from all materials including metal, fabric, glass and plastic.

Experienced design team

With a clear understanding of the complex technical requirements of lighting design, our design team is dedicated to developing bespoke lighting solutions to deliver the unique concepts of our customers and to complement their style and architecture.

In-house manufacturing

With 31,000' square factory in Chesterfield we can accommodate production quantities of 1-1000 and beyond.

Our in-house manufacturing site means a flawless transition from design to production. It also ensures on-time delivery and an immediate response to any changes required by our customers.

Customer service

Customers are always at the very heart of Northern Lights. We have strict project control to make sure every project is delivered on time and is of the highest quality. Our key stage assessments with clients during project development ensure an accurate interpretation of the perceived result.

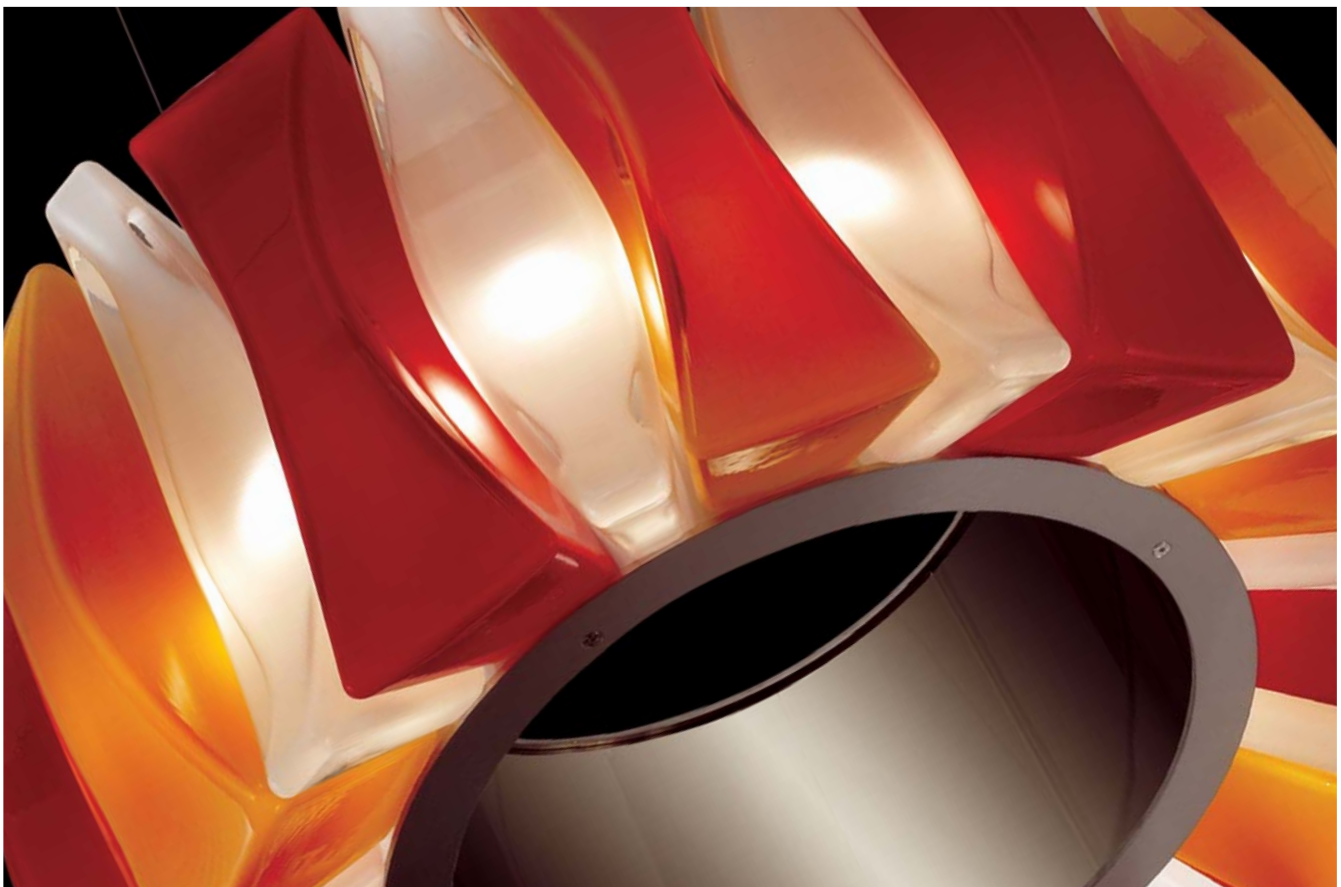

northernlights

Your lighting experts



Concept Development

Interior designers and architects are always exploring new possibilities. So are Northern Lights. When our customers want a particular lighting concept to suit their projects, we are here to develop that concept to reality.

Working process:

- Origination of design brief and specification document
- Concept generation
- Design development
- Design proposal
- Mechanical and electrical engineering
- Product manufacture
- Product delivery

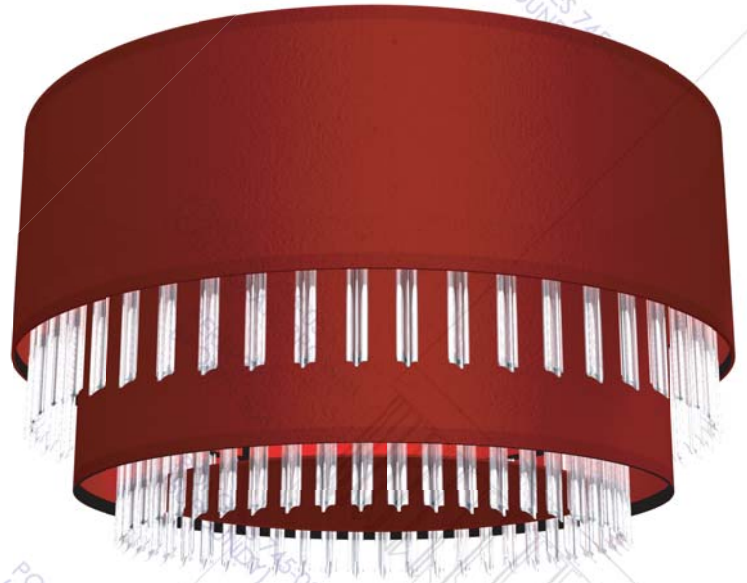

Project Highlights - The Libertaire Club London

Libertaire is a membership club based in West London.

Understated but glamorous was the brief given to Northern Lights. Working alongside with 2C Design Consultants, two custom-made giant pendants were created to meet the brief. The ambient lights behind fabric provided warmth and luxury while crystal drops added a hint of sparkle.

All the custom-made pendants were made in the Northern Lights factory in Chesterfield to ensure the highest quality and attention to detail.

Project: The Libertaire Club London | Design Consultants: 2c Design Consultants

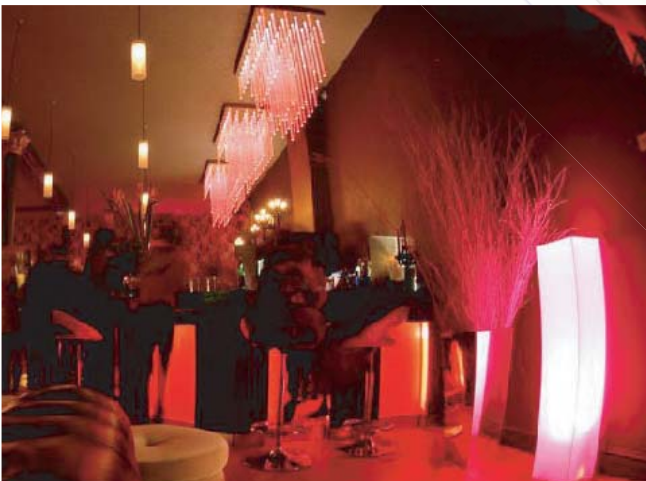

northernlights

Your lighting experts

Product development

In addition to our wide range of standard products, Northern Lights also develop custom-made lighting to complement the interior scheme and room décor.

Our technical knowledge of lighting ensures that the most suitable lamps and luminaires are specified and that the latest government directives for energy efficiency are adhered to.

Product and service range:

- Large scale feature pendants
- Quality engineered fit for purpose
- Specific task lighting
- Indirect lighting solutions
- Multifunctional luminaires
- Bespoke product solutions which are site specific
- Non-standard material and finish options

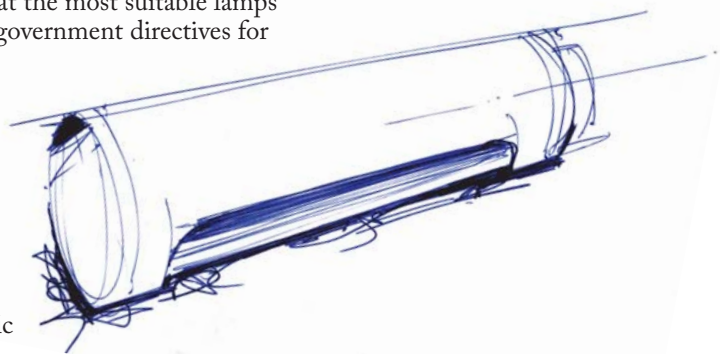

Tubular LED Desk Lamp

Utilising the latest linear compact high output LED technology, Northern Lights have designed and developed a minimalist contemporary styled lighting unit. The unit is a core element which can form the basis of an integrated suite of luminaire types.

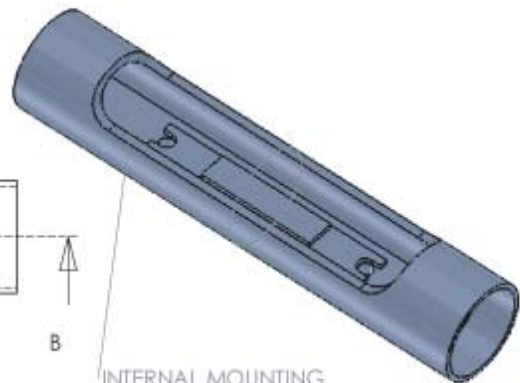
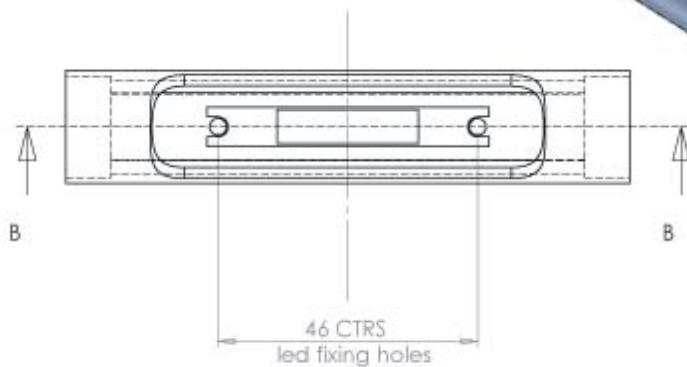
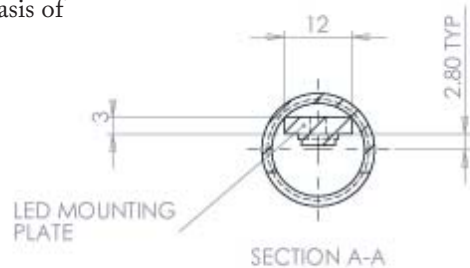
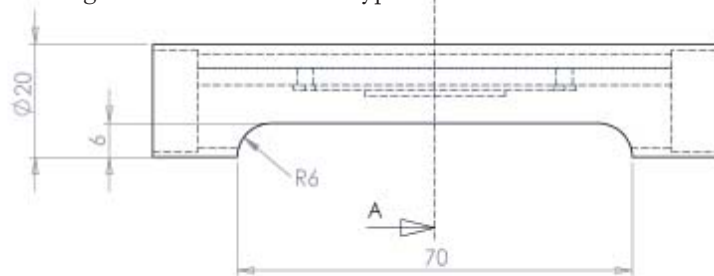

INTERNAL MOUNTING PLATE WELDED INTO POSITION

M3
thro'plate only



Project Highlights - Tubular LED Desk Lamp

Utilising the latest linear compact high output LED technology, Northern Lights have designed and developed a minimalist contemporary styled lighting unit. The unit is a core element which can form the basis of an integrated suite of luminaire types.

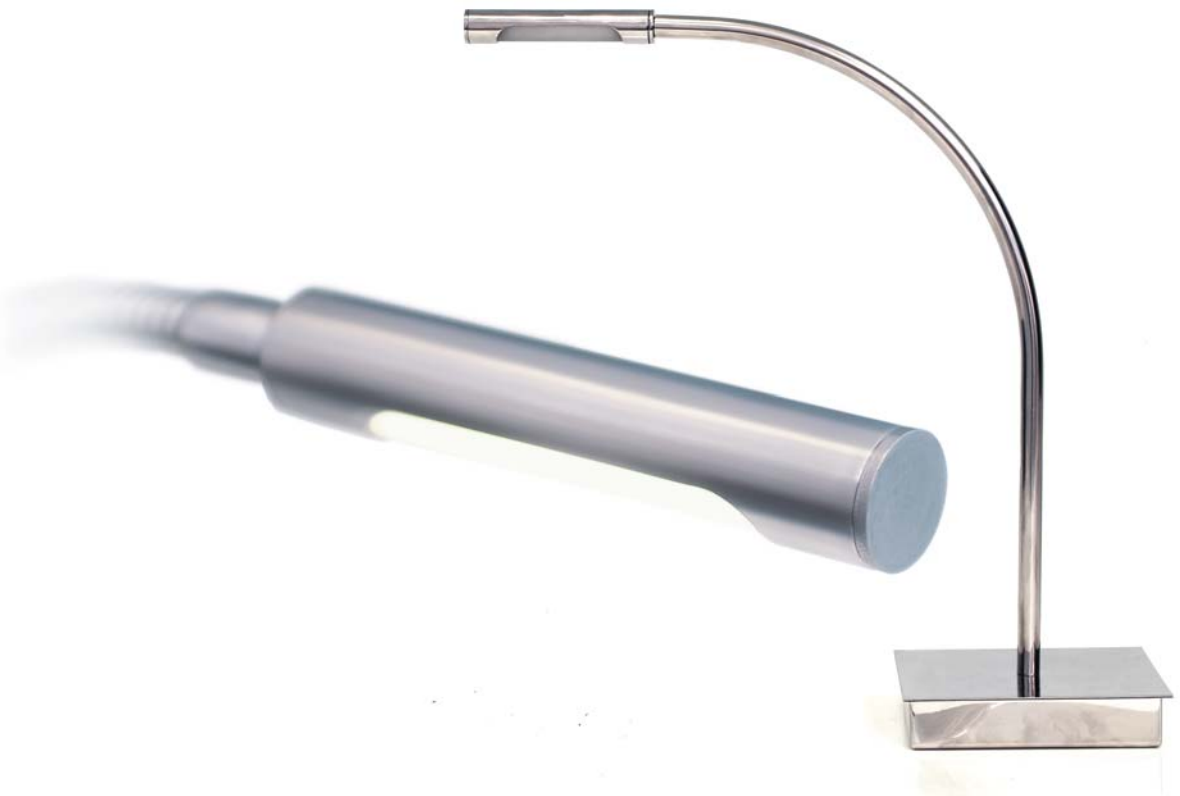

Project Highlights Mercedes Benz Nottingham Show Room.

Concept :

A curved lighting frame system which is concentric to the building, designed to integrate and harmonise with the architectural theme of the showroom. Providing dramatic accent illumination and emphasis of product.

Construction :

Rolled aluminium rectangular tube. The inner row of curved units form an unbroken arc measuring R11500mm, with the outer row of curved units equally spaced to form an arc measuring R19500mm. The frames support adjustable 150W CDM-T floodlight projectors offering lighting flexibility. Colour matched to client specification.

Lamp type:

150W Ceramic Metal Halide – CCT 4200K

Mercedes-Benz
(Nottingham Show Room)

northernlights
Your lighting experts

Lighting Theme Design



Northern Lights can develop a lighting theme that will harmonise with the architectural style and room function to add either subtlety or glamour. We use the latest computer-aided design software to prepare lighting schemes.

We have extensive experience in:

Providing imaginative solutions for colour changing light effects, scene setting and medium/source.

Innovative use of the latest lamp technologies and providing guidance on lamp selection and specification to ensure latest regulations are achieved

Producing detailed lighting layout drawings.

Composition of illuminance data calculation to ensure compliance with light level recommendations



Concept:

A custom built product designed around the space of the handover bays, engineered to accurately and evenly illuminate the vehicle with the use of a dedicated reflector lamp. Designed to reflect an automotive theme.

Construction:

Tubular aluminium housing with fixed lamp-retaining mechanism.

Lamp type:

70W CDM-R111 – CCT 3000K

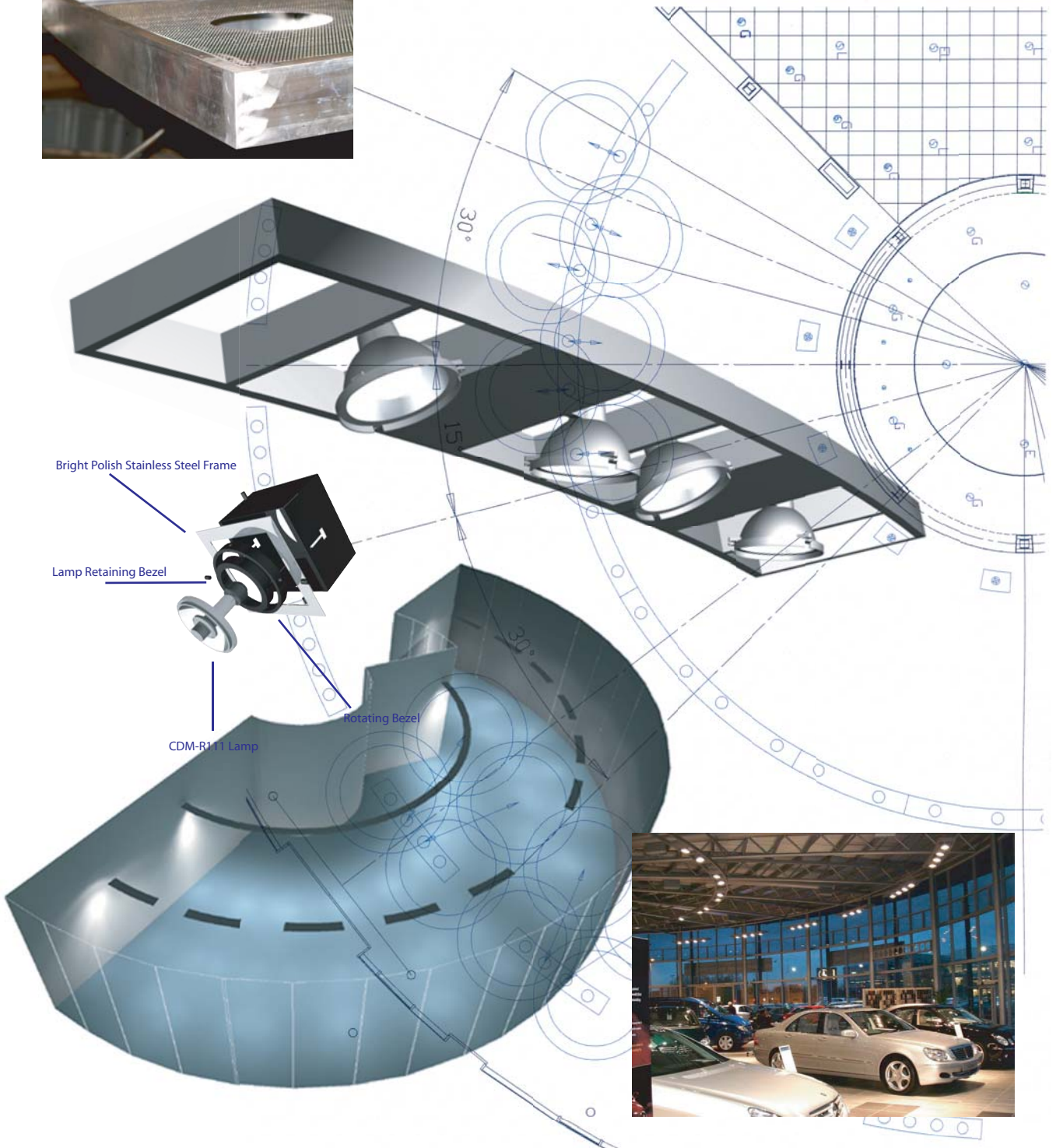

Lighting Simulation

Our experienced professional lighting designers can help you put together a lighting proposal for both internal and external lighting.

Your sketches and drawings



Lighting design development

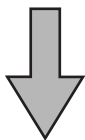

Lighting proposal

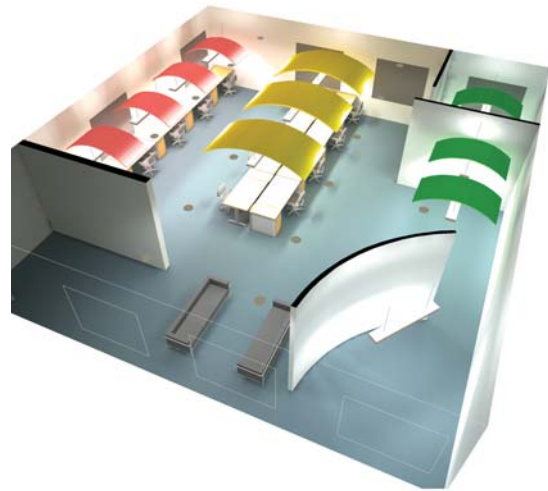

Internal lighting proposal

PTI SOUTH MIMMS
Lighting proposal - 01



Ref: A: Ground mounted uplight
50W AR111 IRC 8degree beam

Ref: Ab: Ground mounted uplight
50W AR111 IRC 8degree beam
Coloured filter accessory



Ref: B: Surface mounted narrow beam spotlight.
70W CDM-T
Coloured filter accessory

Luminaire schedule:

Ref:A - 14No. @ 50W
Ref: Ab - 6No. @ 50W
Ref: B - 2No. @ 70W

Total loading: 1.14kW

External lighting proposal

You will be able to incorporate different lighting styles into the lighting theme so that you can make a decision based on the photo-realistic drawings. You will be confident about the desired result from the start.



At any venue, it is essential that the right level of light is given to any surface or work plan to prevent glare to customers, to create the right ambience and to provide good task lighting. We can provide you with an accurate indication of light levels using Relux professional lighting calculation software.

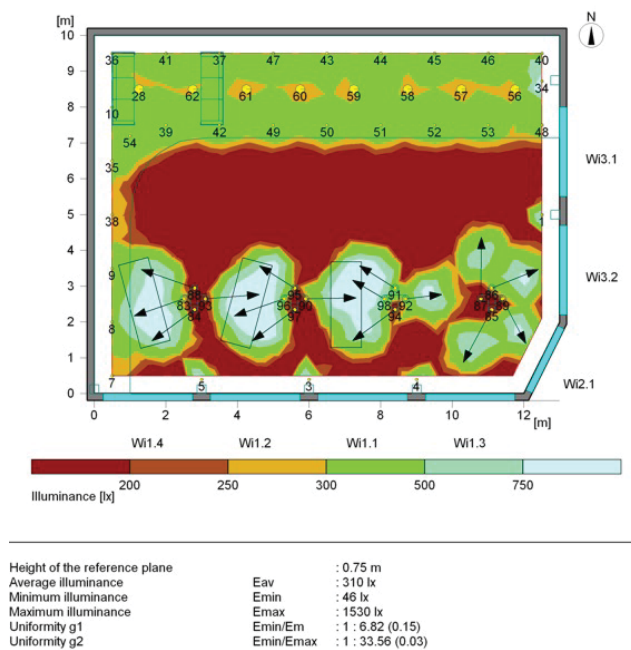

Light level indication produced by Relux lighting calculation software